

Mammograph FFDM



PRODUCT DATA

Product data

Mammograph FFDM – Rev.1 (May 2010)

	Page
Description and Configurations	3
Technical Features	7
Mammography Unit	8
Acquisition Unit	12
Diagnostic Unit (Optional)	12
Size and Dimensions	13
Classifications	16
Installation and warranty	16

DESCRIPTION

Mammograph FFDM is the new Itarray solution for clinical mammography (from mammograms to stereotactic biopsy) with the strong improvement of *direct digital imaging*.

Direct detection, allowed by the Amorphous Selenium detector (that transforms directly X-ray into electric charges), avoids the light diffusion effect that degrades image quality and produces a precise signal profile that preserves image sharpness.

Quality and diagnostic content of image are improved with a particular compression device, softly curved and with smooth lines that grants for higher patient comfort and that can be both motor and manually driven.

Mammograph FFDM is also equipped with a double display showing values of compression effect, like applied force and reached breast thickness.

The strong effect of a good compression is completed with the big area of Flat panel detector (max. 24x30 cm) and its deep resolution (2816x3584 pixels).

The system is totally microprocessor controlled and its asymmetry facilitates operator access together with patient control into a small space too .

Direct Digital technology not only allows for better images, as well as reducing times for achieving an X-ray image, it interfaces the system to the Hospital Informative System for scheduled workflow, patient information and images that, once acquired, can be directly send both to a DICOM printer and to the RIS.

This new unit is composed of:

- **Mammography Unit:** tube stand with fully motorized C-Arm, X-Ray tube and Direct Conversion Amorphous Selenium detector (18x24 cm or 24x30 cm format); either non Isocentric or Isocentric C-Arm usable for Stereo biopsy in combination with BYM 3D FFDM Stereo biopsy device;
- Integrated X-Ray control and **Image acquisition station**;
- Viewing and Reporting **Diagnostic station** (optional).

Following , each unit is described in details:

MAMMOGRAPHY UNIT:

- High frequency X-Ray generator (Frequency: 100 kHz– Power: 5 kW)
- Fully motorized C-Arm with:
 - Up/Down movement with travel of 70 cm
 - Rotation on 5 pre-selectable angles (changeable by operator)
 - Continuous rotation up till desired angle (CW/CCW +/- 180° Range)
- Non Isocentric C-Arm with fixed focus-detector distance of 66.2 cm
- Isocentric C-Arm with fixed focus-detector distance of 66.7 cm and motorized rotation for stereo angles +/-15°
- X-Ray tube with tungsten biangular anode (2 focal spots: 0,1 and 0,3 mm and automatic filters: 50 µm Rhodium/50 µm Silver)
- Direct Conversion Full Field Flat Panel Detector (Amorphous Selenium): 18x24 cm or 24x30 cm format
- Automatic Exposure Control (AEC)
- AGD (Average Glandular Dose) calculation
- Advanced and comfortable compression device:
- Removable anti-scatter grid
- Device for geometric magnification (1,5x or 2x factor) without anti-scatter grid and with automatic selection of small focal spot
- Microprocessor control desk
- Control panel with graphic display
- Integrated auxiliary display with "C" arm inclination, ACR projections, compression force selected/applied, breast thickness and laterality selection
- Two emergency STOP push-buttons



ACQUISITION STATION:

- With transparent anti-X protective barrier for operator
- Acquisition software complete of:
 - Motorized mammo control panel
 - Off-line images display and viewing
 - Patient information local DataBase
 - Mammo tools to set the exposure parameters and the ACR view
 - PC tools to make operations on the local PC of the acquisition station:
 - Graphic tools to manipulate images (Fit to window, Zoom, Pan, Magnification lens)
 - GOP® images enhanced (GOP® is a post-processing algorithm specific for mammography that enhance the quality of the acquired images)
 - DICOM tools (DICOM 3.0 conformity)
- 2 MPixel Colour LCD Display System (20.1" viewable size)
- HIS-RIS-PACS Interface

**DIAGNOSTIC STATION (OPTION):**

The Viewing/Reporting Station is available in option.

- Workstation with DVD Recorder
- Very high resolution 5 MPixel Medical Dual Headed Digital Flat Panel Display System (21.3" viewable size)
- Software for images management and processing:
- DICOM 3.0 MG Conformity:
- LCD Colour Service Display System (19")
- HIS-PACS-RIS Interface

TECHNICAL SPECIFICATIONS:

POWER SUPPLY	
Line voltage	220/230/240Vac ±10% 50/60Hz
Power	6.6 kVA (0.5 kVA stand-by)
Current absorption	30 A peak

ENVIRONMENTAL CONDITIONS	
Storage and delivery conditions	Detector special transport package
Operating conditions	temperature + 20° C / + 25° C (24 h) barometric pressure 700 hPa/1060 hPa (24 h)
Protection degree according to standard IEC 529	IP 10
Heat dissipated in max load condition of 35 kV 300 mAs (1 shot every 5 minutes)	316 kCal/h

OPERATING ENVIRONMENTAL CONDITIONS	
Full field Flat Panel Detector strictly bounds operating conditions, since working temperature has to be stable in order to grant for: better quality of image, long lasting calibrations, long life of detector.	
Operating temperature	From +15 to +35 C°.
Storage temperature	From +10 to +40 C°.

ENVIRONMENT PROTECTION AND WASTE DISPOSAL	
Device contains in some of its parts and subassemblies, solid and liquid substances that must be disposed only by designated companies according to local laws. More specifically, device contains:	
Tube assembly	Beryllium, lead, glass, dielectric oil (PCB free), other metals and plastic.
H.V. transformer	Dielectric oil (PCB free), plastic, copper other metals
Other subassemblies	Plastic, other metals, electronic components glass-epoxy printed circuits, amorphous selenium

MAMMOGRAPHY UNIT: Technical Features

H.V.GENERATOR	
Output Frequency	100 kHz
Power	5 kW
kV range	20 / 35 kV
kV resolution (Man & Auto mode)	0,5 kV
kV precision	±1%
kV repeatability	± 0,1%
kV display	XX,X kV (3 digits)
mAs Range	1 / 640 mAs
mAs resolution (Automatic)	0,1 mAs
mAs values in accordance with R'20 series	1, 2, 3, 4, 5, 6, 7, 8, 9, 10, 13, 16, 20, 25, 32, 40, 50, 63, 80, 100, 130, 160, 180, 200, 250, 300

X-RAY TUBE ASSEMBLY (I.A.E. XM1016 T)	
Anode rotation speed	3000 rpm 50 Hz
Target material	Tungsten+Rhenium Molybdenum+Titanium+Zirconium
Maximum Anode Heat Content	300 kHU
Maximum X-Ray Tube Assembly Heat Content	425 kHU
Housing continuous Heat Dissipation	80 W (108 HU/s)
Cooling method	free air convection
Anode Disc Target Angle	10°/16°
Anode Disc Diameter	80 mm
Power	5600 W large 1400 W small
Nominal X-Ray Tube Voltage	35 kV
Highest X-ray Tube Current available at 35 kV (IEC 601-2-45 par. 6.8.2-1)	105 mA
Highest X-Ray Tube Current	105 mA
Highest X-ray Tube Voltage available at 100 mA (IEC 601-2-45 par. 6.8.2-2)	35 kV
Combination of X-Ray Tube Voltage and X-Ray Tube Current which results in the highest electric output power (IEC 601-2-45 par. 6.8.2-3)	35 kV*105 mA=3675 W
Focal spots (spot size according to IEC 336)	0,1 small 0,3 large
mAs range	Small focus: 1÷130 mAs (from 20 to 30 kV) 1÷100 mAs (from 31 to 35 kV) Large focus: 1÷300 mAs (from 20 to 35 kV)
Inherent filtration	0,0 mm Al IEC 522/1976
HVL measured at 28kV	>0,3 mm Al equiv.
Total filtration	>0.5 mm Al
Filtro	50 µm Rhodium
Tube assembly thermal overload protection	With active temperature sensor under main CPU control

FILTER PROPERTIES	
50 µm Rhodium	0.51 mm Al eq @ 28 kV, measured with W target
50 µm Silver	0.55 mm Al eq. @ 28 kV, measured with W target

DIGITAL FLAT PANEL DETECTOR	
Top Cover	Carbon fiber 0.1 mm Al equivalent
Technology	Amorphous Selenium (a-Se)
Pixel Pitch	85x85 μm
Resolution	2016x2816 (18x24 cm format) 2816x3584 (24x30 cm format)
Active Area	17.2x23.9 cm (18x24 cm format) 23.9x30.5 cm (24x30 cm format)
Selenium thickness	200 μm
Depth	13 bit
MTF (Modulation Transfer Function)	52 % a 5 lp/mm
DQE (Detector Quantum Efficiency)	0.58 (@ 1 lp/mm for exposure of 10 mR) 0.22 (@ 5 lp/mm for exposure of 10 mR)
Read Time	< 1.4 s
Time Between X-Ray Images	< 15 s (24x30 cm)

GRID	
Bucky factor	1,85
Ratio	6:1
Lines/cm	36
Contrast factor	1,54

C-ARM	
F.D.D. (Focus Detector Distance)	66.2 cm
Rotation	Manual $\pm 180^\circ$ with disc brake
Display of angle rotation	On control panel and on auxiliary display
Vertical movement with respect to Breast support (C-ARM in vertical position)	618 mm min to 1323 cm max
Protection of examination field	Removable lexan screen

ISOCENTRIC C-ARM	
F.D.D. (Focus Detector Distance)	66.7 cm
Rotation	Manual $\pm 180^\circ$ with disc brake
Display of angle rotation	On control panel and on auxiliary display
Rotation for biopsy projections	Motorized $\pm 15^\circ$ microprocessor controlled
Vertical movement with respect to Breast support (C-ARM in vertical position)	750 mm to 1450 mm
Protection of examination field	Removable lexan screen

COLLIMATOR	
Light beam	Switch ON by push-button or automatic when operating compression (selectable by service) Electronic timer
Light intensity	≥ 150 lux
Light beam collimation accuracy	according to IEC 601-1-3
Mirror	with automatic out of field function
Collimation format	18x24 cm or 24x30 cm or magnification

COMPRESSION SYSTEM	
Compression Plate movement	Manual or motor driven
Compression Plates (standard for 18x24 cm)	18x24 cm shifted for normal breasts 9x21 cm straight for magnification
Compression Plates (standard for 24x30 cm)	18x24 cm shifted for normal breasts 24x30 cm shifted for large breasts 9x21 cm straight for magnification
Maximum free space available between Compression Plate and image receptor	325 mm with shifted Compression Plates In Magnification Mode (straight compression plate) MAG. X 1.5 = 231 mm MAG. X 2 = 131 mm
Compression Thickness Display	Displayed in mm
Compression Force Adjustment	Adjustable from 0 to 15 kg or 20 kg
Compression Force Display	Effective applied force with 0.1 kg resolution
Maximum Compression Force Safety	Triple safety device: electronic, electro-mechanical, mechanical
Compression Holder	Fast mechanical unlock
Compression plate release after exposure	Selectable from control panel, automatic or manual for 2D biopsy
Compression plate aluminium equiv.	Less than 0.2 mm Al (0.135 mm Al 30 kV)
Special function for 0 compression force for oncology procedures	

MAGNIFICATION	
Top Cover	Carbon fiber 0.1 mm Al equivalent
Magnification ratio (variable)	x1,5 / x2

FOOT PEDALS	
For compression	Two pair

EMERGENCY STOP/SHUTDOWN SWITCHES	
Red push-buttons	On both sides to switch the unit totally off

DOSE CALCULATOR	
Calculated dose	Average Glandular Dose (AGD) according to: "D.R. Dance et al."
Data visualization	On display, on Acquisition Work Station

CONTROL PANEL	
Technology	Microprocessor controlled with unique safety features exceeding IEC 601-1-4, all functions under active operator control
Display	GRAPHIC LCD Display 240x128 dots
Alarm messages	In several languages selectable
Special features	Tube Thermal Unit display and active protection. Technical display for self-test and defective block identification, firmware release, exposure counter and last exposure time/date.
Statistics function	Average dose, amount of exposure for every kV value, amount of exposure in every test technique
Diagnostic functions	Selectable service functions on LCD Display for hardware testing of each specific board with input status display, single status display and ON/OFF function

ACR DISPLAY	
Display	3 displays (7 segments) + 18 Leds
Informations	C-arm rotation angle Compression thickness Compression force Projection

ACQUISITION STATION: TECHNICAL FEATURES

ACQUISITION STATION	
DICOM Interface	3.0 MG modality IHE conformity for the PIR, SWF and mammography profiles
Anti-X protection screen	Integrated Pb equivalence > 0,34 mm @ 35 kV

HIGH RESOLUTION LCD COLOUR DISPLAY (2 MPIXEL)	
Display Type	LCD Active Matrix Flat Panel Display (TFT)
Viewable Size	20.1" diagonal
Display Resolution	1600 x 1200 UXGA
Pixel Pitch	0.27 mm
Contrast Ratio	500:1
Brightness	300 cd/m ²
Viewing Angle	160° H/V
Response Time	25 ms (15 ms rise, 10 ms fall)
Palette	16.7 million colours
Refresh rate	56 to 85 Hz

DIAGNOSTIC STATION (OPTIONAL): TECHNICAL FEATURES

DIAGNOSTIC STATION
DICOM, RIS, PACS, DATA STORAGE
Advanced Images Manipulation Tool Set

VERY HIGH RESOLUTION DUAL HEADED DIGITAL FLAT PANEL DISPLAY SYSTEM (5 MPIXEL)	
Display Type	AMLCD (Active Matrix Liquid Crystal Display)
Viewable Size	21.3" diagonal
Display Resolution	2048 x 2560 pixels (portrait) 2560 x 2048 pixels (landscape)
Contrast Ratio	600:1
Brightness	700 cd/m ²
Viewing Angle	170° H/V
Grey levels	3061

SIZE AND DIMENSIONS Mammography Unit

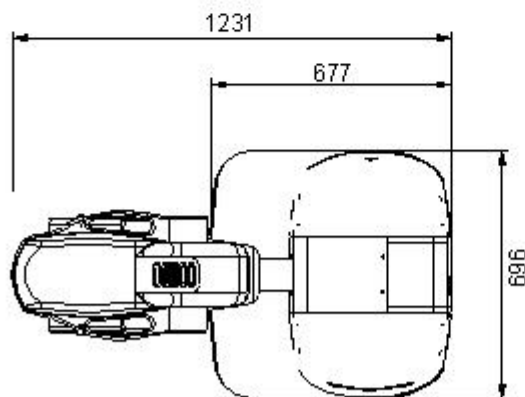
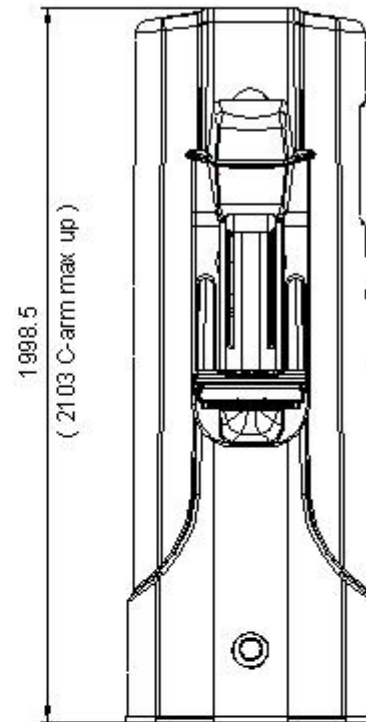
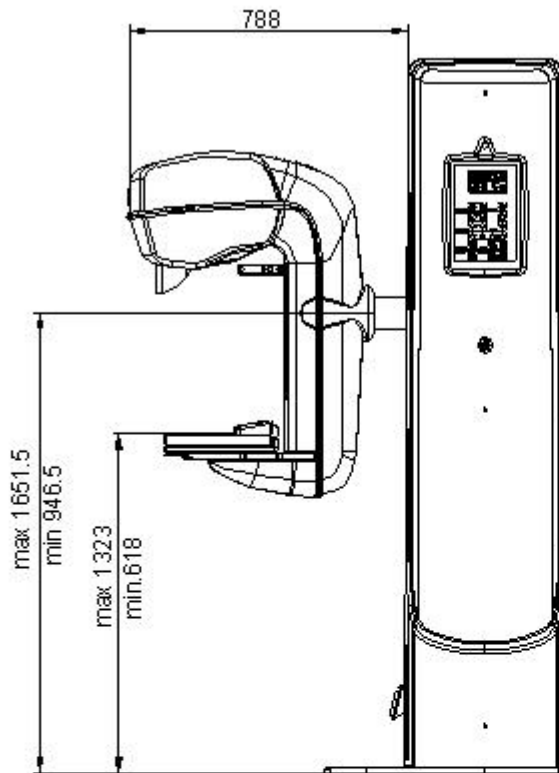

Mammography Unit with BYM device

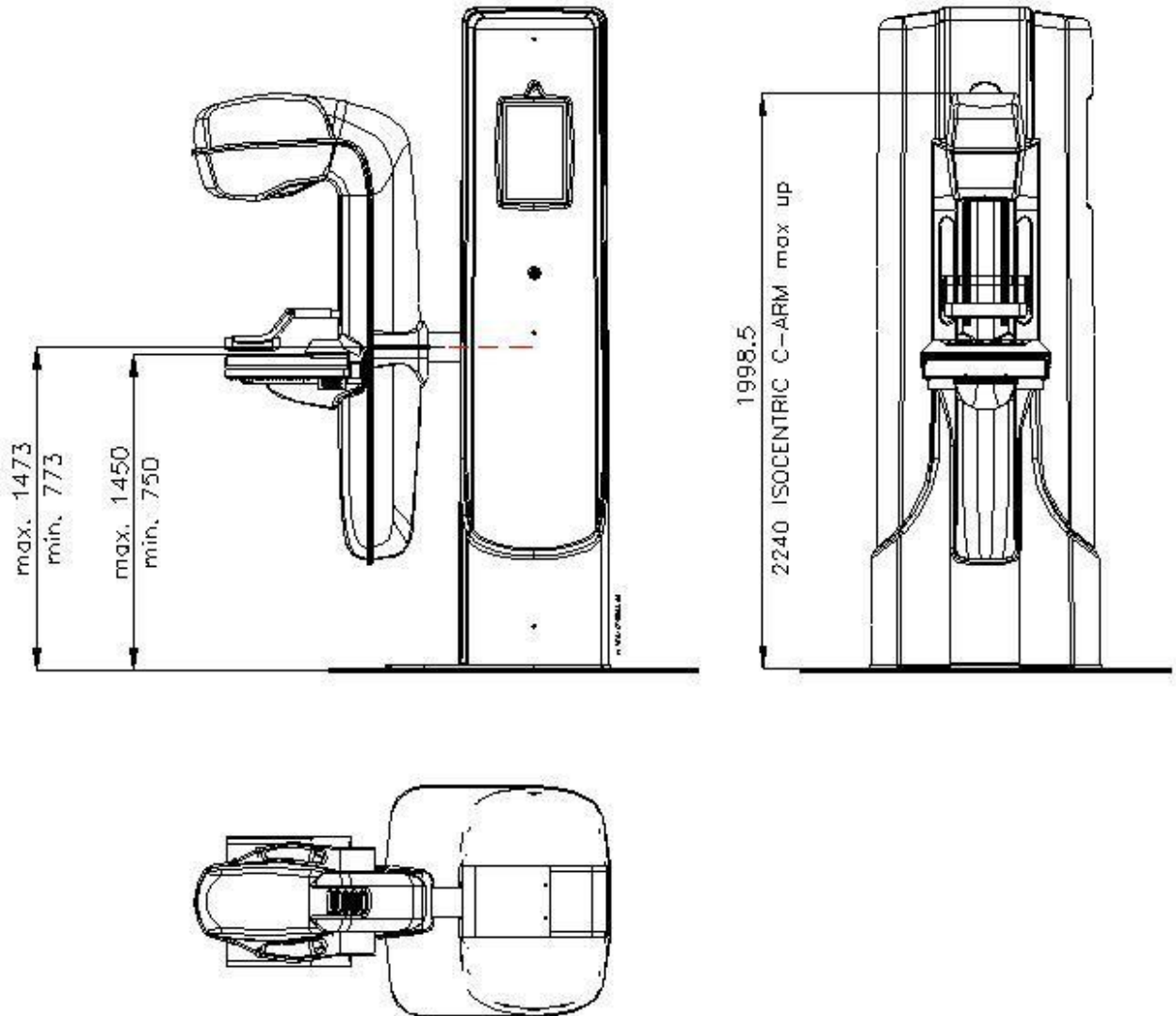

Acquisition station

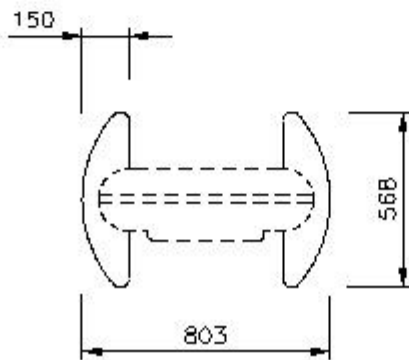
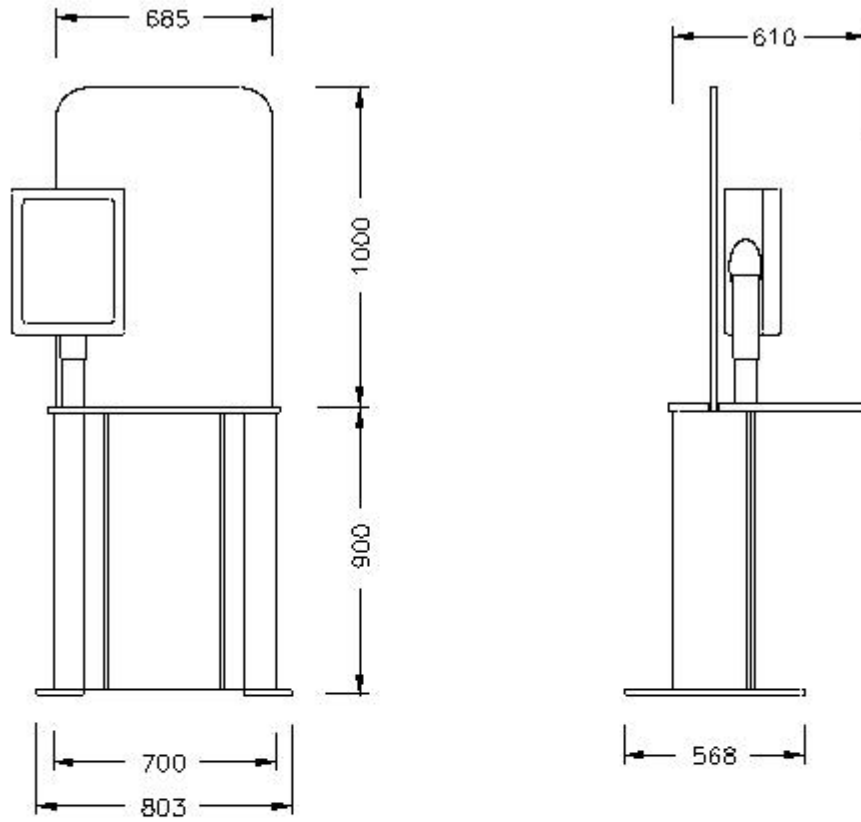

CLASSIFICATION

Mammograph FFDM has been designed, built and tested accordingly to European directives: 93/42 CEE, 89/336 CEE.

This device is a Class 2 b device, by the EEC 93/42 and a Class I type B by the CEI EN 60601-1.

ITALRAY is certified according to international standards: UNI EN ISO 9001:2008 (certificate n° CERT-10119-2002-AQ-FLR-SINCERT) , UNI EN ISO 13485:2003 (certificate CERT-03181-98-AQ-IND-SINCERT) by Det Norske Veritas (DNV).

NOTE:

BYM3D FFDM is a device having its own CE certificate according to Medical Device Directive 93/42/CE and not conditioning X-Ray emission.

INSTALLATION AND WARRANTY

Mammograph FFDM device can be installed in pre-existing diagnostic room or in a new room, only by our technician staff or by authorized technical personnel that has been appropriately trained by ITALRAY.

Italray technical staff can provide the best position plan of Mammograph FFDM. Upon request, ITALRAY Installation Office can prepare installation layouts (including eventual construction and electrical). ITALRAY can offer to its customers a wide range of service plans that will perfectly fit customer needs and preferences.

Because of the peculiar technology of digital flat panel detector, system warranty has to be cancelled whenever there is an abnormal functioning due to detector operating use out of the suggested temperature limits.

PACKING AND TRANSPORT

Mammograph FFDM can be packed in two different ways.

- *For sea transport:* wooden case with barrier bag.
- *For normal transport:* wooden case.

Device or configurations can change without notice



Via Del Parlamento Europeo 9/D 50010 Scandicci Firenze
tel. +39/055/7228511 fax. +39/055/7228512

www.italray.it email info@italray.it